

Hybrid Welding of Large, Complex Parts
Laser Plastic Welding with LPKF TwinWeld3D

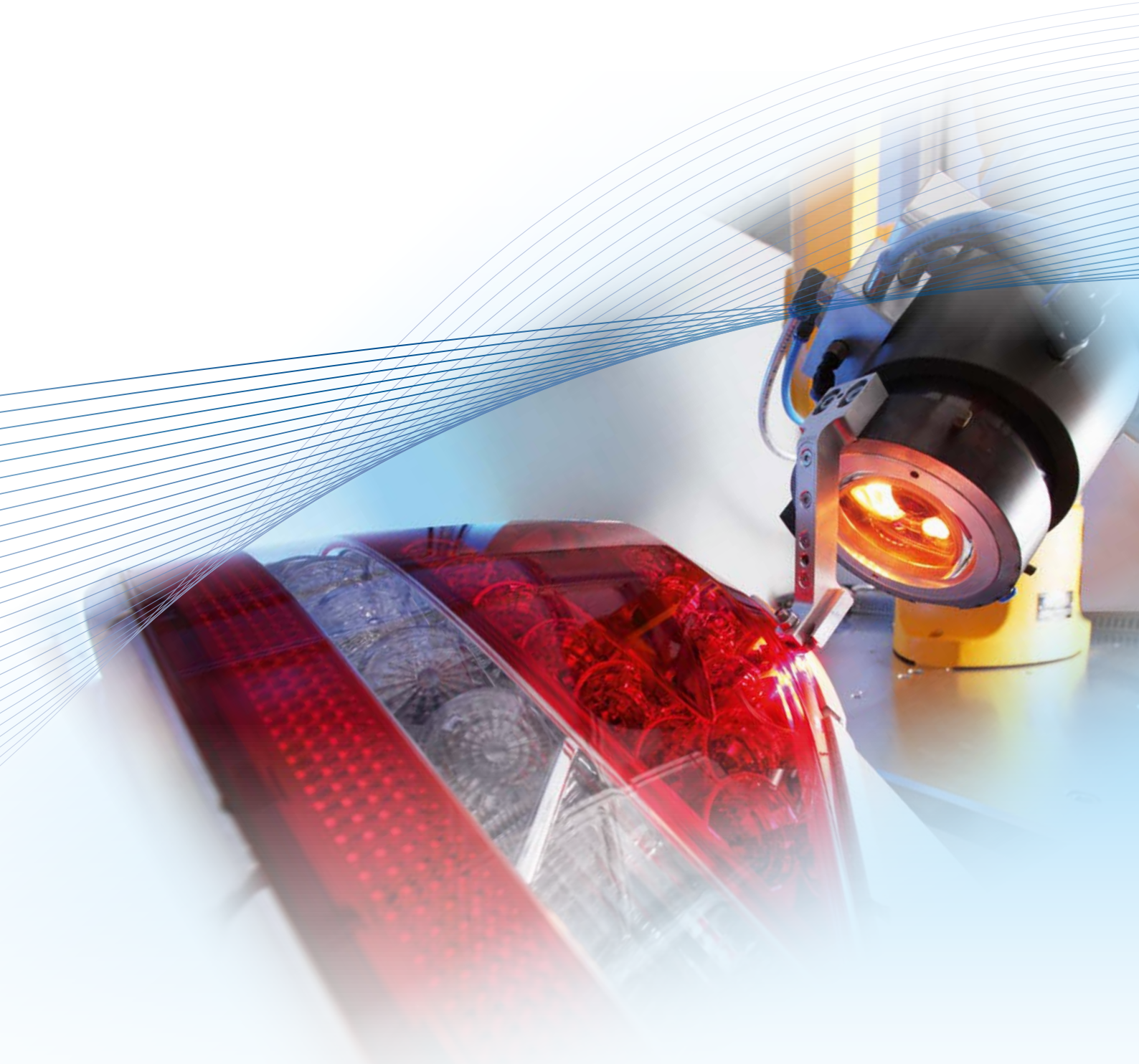

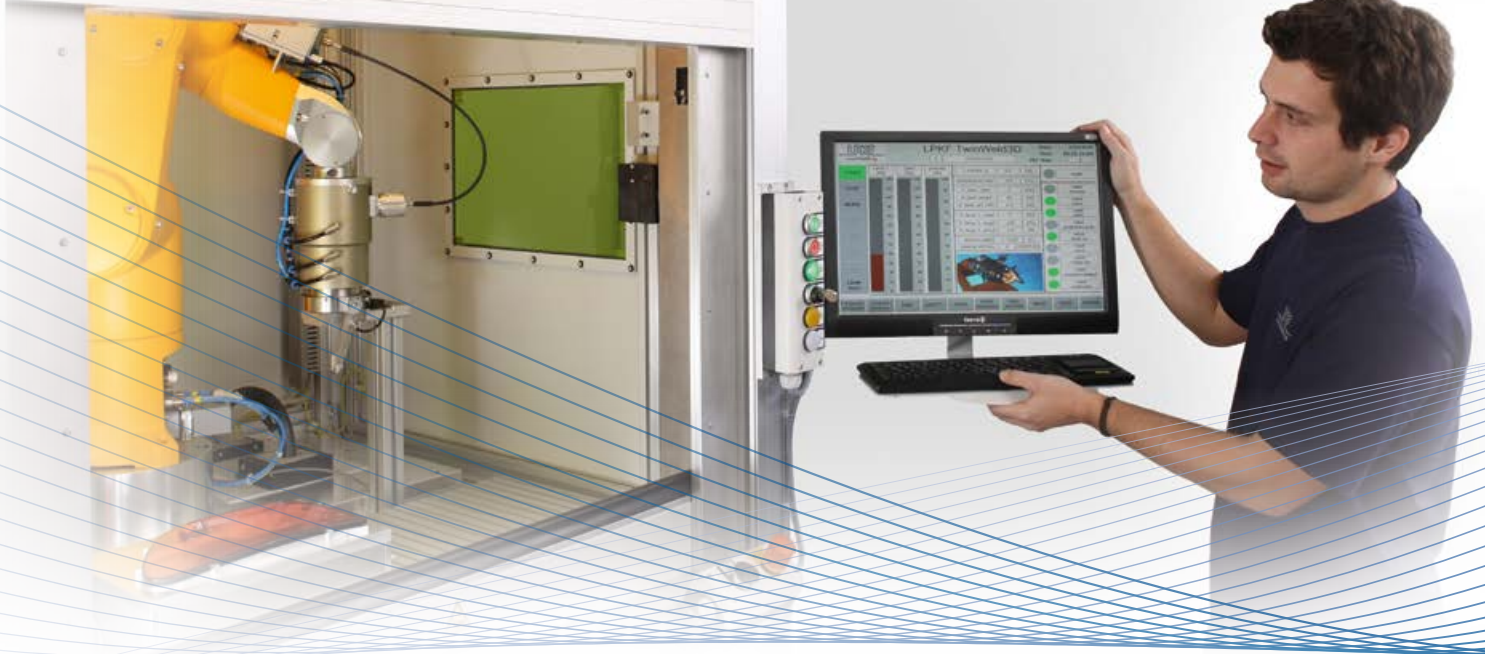

LPKF
Laser & Electronics



Quality and Productivity

Wish list: better seams, higher flexibility and lower costs. The LPKF TwinWeld3D plastic welding system has all this and more: perfect welding of large components and low unit costs. The innovative laser hybrid welding system has revolutionized the volume production of tail lights in the automotive sector.

One Laser System, many Advantages

The secret of welding plastic with a laser beam lies in the precise control of the beam energy. LPKF does this in a new way: with the LPKF hybrid welding system, the welding process takes place in a thermal field. This produces optically and mechanically enhanced welding seams, higher processing speed, and new options for designers and engineers.

Now in its second generation, the LPKF TwinWeld3D joining system superbly demonstrates its capacity for the industrial production of large components – with high machine availability. The use of laser safety glass in the housing window gives the system a laser class 1 rating.

Cost-oriented Production

LPKF hybrid welding improves budgets even before a single part has been produced: the costs for welding tools drops considerably compared to other methods. A tensioning roller applies the necessary joining pressure. The project-specific costs sink to the production of a simple workpiece holder.

Production costs are also reduced: the annealing process, previously essential when manufacturing stress-crack-sensitive components such as car tail lights, is now completely unnecessary. All this means: lower unit costs, and economical production of even small numbers of pieces.



LPKF TwinWeld 3D 6000

As much Pressure as Necessary

A defined clamping pressure is always required in the laser plastic welding process. This is provided by the hybrid welding head, so that expensive upper dies are no longer required.

The integrated air-sprung joining roller applies a constant vertical clamping pressure to the parts being joined. This roller runs over the component parallel to the welding process. The tensioner is cooled and uncoupled from the rotary movement of the welding equipment – to guarantee perfect product surfaces.



- Low-maintenance welding head
- Smaller space requirements
- No clamping tools needed

LPKF Hybrid Welding versus Hot Plate Welding

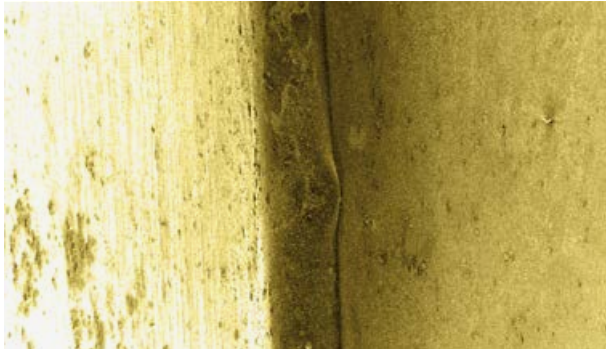

LPKF hybrid welding wins every time with a compact joint (50 x magnification).

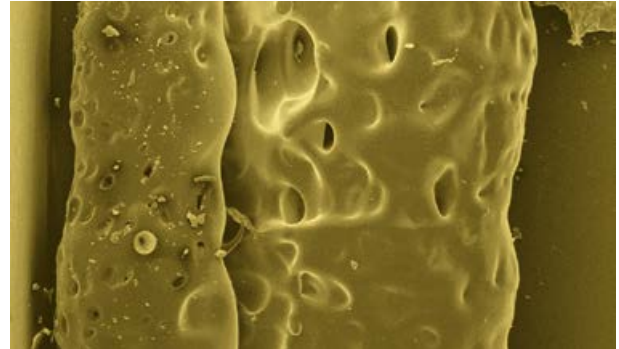

Massive melt blow-out and inhomogeneous structures during hot plate welding (50 x magnification).

LPKF Hybrid Welding versus Vibration Welding

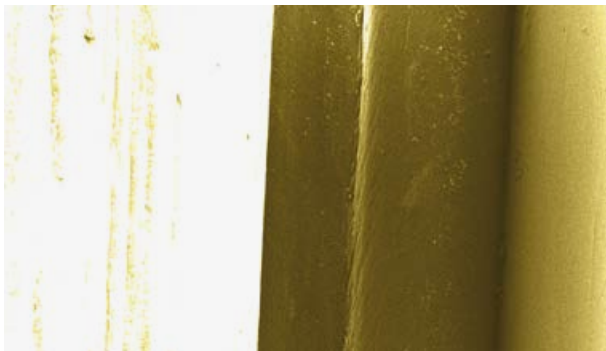

A perfect welding seam produced by LPKF hybrid welding (150 x magnification).

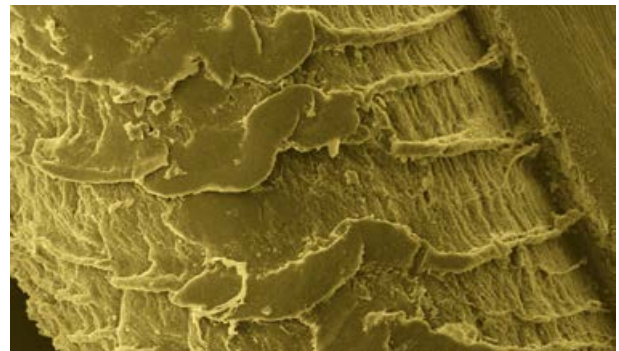

Vibration welding produces a scaly structure with the formation of particles at the margins (150 x magnification).

Intelligent Combination

In the laser plastic welding process, the laser beam passes through the laser-transparent joining partner and melts the surface of the underlying laser-absorbing part. Thermal conduction then melts the adjoining surface of the upper part, and a defined clamping pressure creates a strong reliable joint.

In the patented LPKF hybrid welding technique, special halogen lamps apply extra energy to the welding zone through polychromatic radiation. This halogen/laser combination increases the processing speed and creates superb looking welding seams. It also reduces the internal stresses. LPKF hybrid welding can therefore do what other welding methods fail to do: produce reliable, perfect, and almost stressless welding seams without any additional treatment.

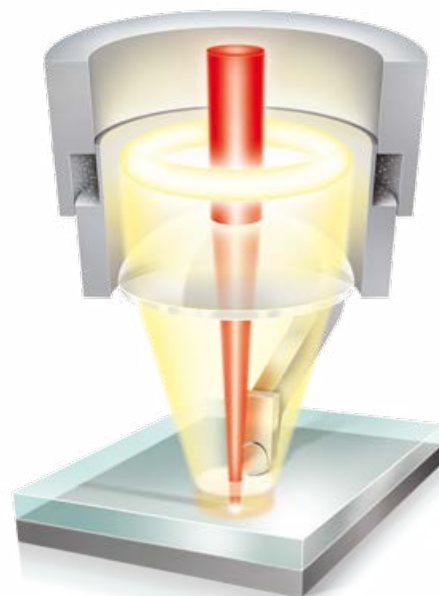

- High quality seams in visible locations
- Particle-free welding
- Flexible contour guidance
- Lower unit costs



Ultramodern light-guiding technology – welded by the LPKF TwinWeld3D 6000

Brilliant Insights

LPKF hybrid welding has already impressively demonstrated its class in the industrial production of car tail lights. The LPKF TwinWeld3D is also very interesting for the production of other components which require top quality welding seams. By using a special PP blend, it is also possible to weld car headlights with the classic polycarbonate – polypropylene material combination.

New Technological Dimension

Something very special was required: the Hyundai Equus – the flagship model of the Korean carmaker – sets itself apart from its competitors with its light design. In a joint project with LPKF, SL Corp. in Deagu, South Korea, developed a tail light which produces spectacular effects with ultramodern light-guiding

technology. The function groups are working together closely to create a three-dimensional effect. This is beyond the realms of conventional welding methods. The LPKF TwinWeld3D can place the welding seams in the visible area – seams so perfect that they are an integral part of the design concept. The welding seams boast levels of brilliance and precision unmatched by any other method.

“Thanks to the LPKF hybrid welding technique, SL Corp. has not only produced welding seams with previously unheard of quality, it also dramatically reduced the reject rate.”

Simyun Sung, Manager SL Corp.

Worldwide Service & Support

24/7 in an industrial environment – no problem for LPKF's successfully tried and tested laser welding systems. For your support we have: highly trained service staff around the world available for commissioning and servicing; an Application Center to help with feasibility studies and machine concepts; job-shop production to tackle production peaks and volume production start-ups. More than just laser welding: LPKF creates solutions – together with its clients.

Technical Data: LPKF TwinWeld 3D 6000

Laser class	1
Beam source	100 W
Laser wavelength	980 nm
Working area	750 mm x 500 mm (29" x 20"), other options available
Power supply	400 V – 3 Phase/N/PE, 16 A, max. 4 kW
Compressed air	6 bar
Ambient conditions	Max. ambient temperature: 35 °C (95 °F); max. air humidity: 80 % at 25 °C (77 °F)
Cooling	Integrated air re cooler
Options	Rotary table, Proportional pressure control valve, Remote servicing
Main dimensions (W x H x D)	2000 mm x 2200 mm x 2500 mm* (79" x 87" x 98")*
Weight	3000 kg (6614 pounds)

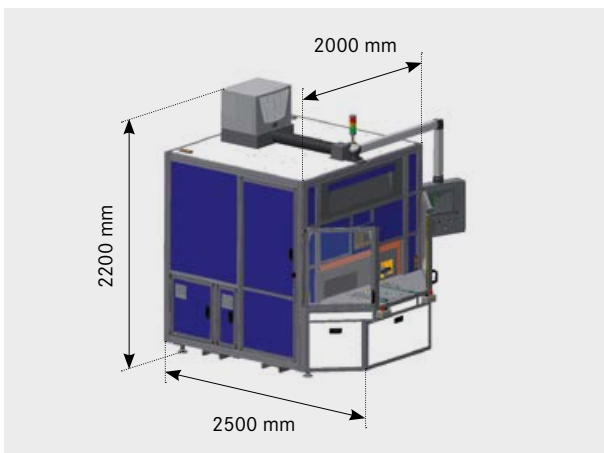



LPKF Service & Support

LPKF provides worldwide premium customer support. Learn more: www.lpkf.com/support





LPKF WeldingEquipment GmbH

Alfred-Nobel-Str. 55 – 57 90765 Fürth Germany
 Phone +49 (911) 669859-0 info.laserwelding@lpkf.com
www.lpkf.com

Part of LPKF Group



Made in Germany