

3-Dimensional Circuitry  
Laser Direct Structuring Technology (LPKF-LDS™)  
for Moulded Interconnect Devices

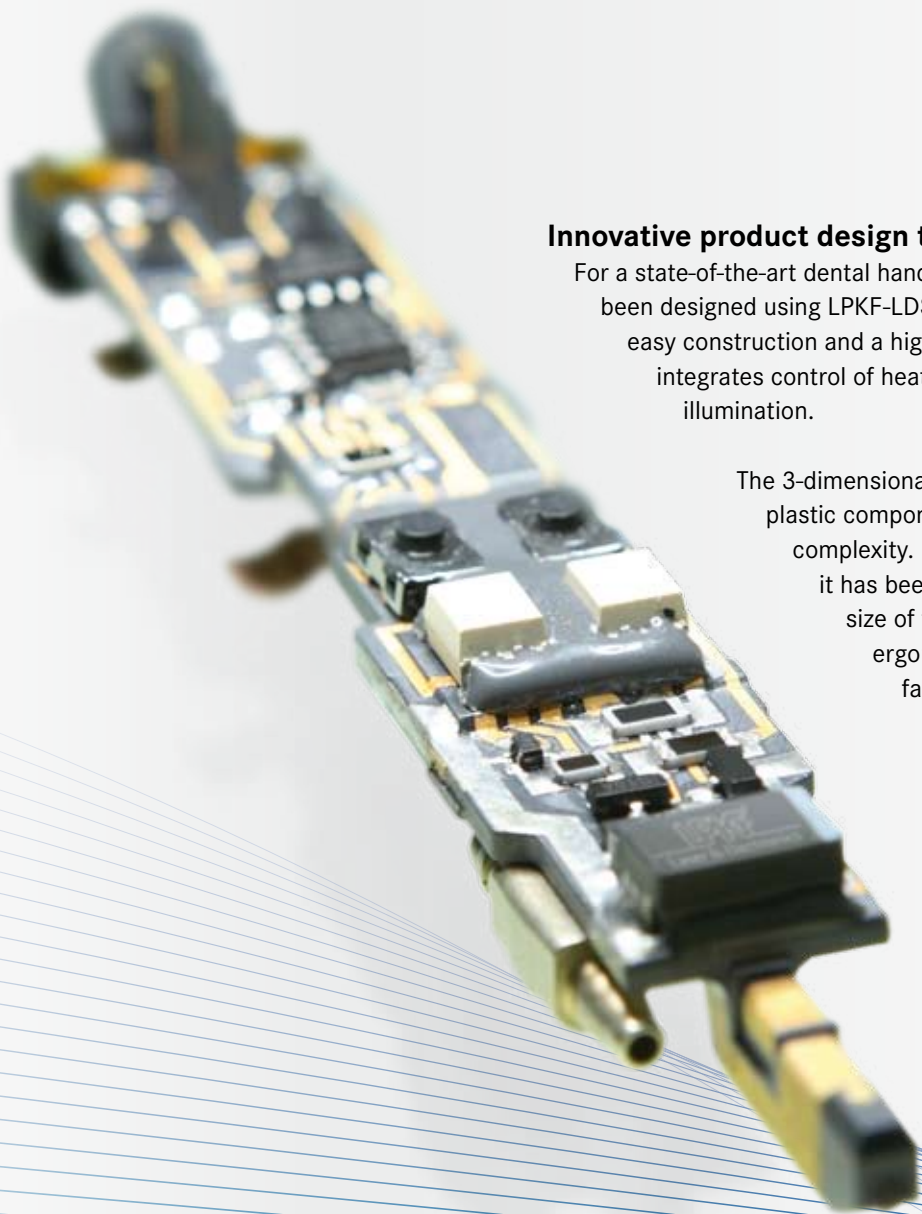



### **Innovative product design through MID technology**

For a state-of-the-art dental hand-piece the basic attachment board has been designed using LPKF-LDS™ technology. This enables compact, easy construction and a higher level of functionality. The device integrates control of heated water supply, air supply and special illumination.

The 3-dimensional circuitry performed directly onto the plastic component eliminates cables and reduces complexity. Benefiting from the LPKF-LDS™ process it has been possible to reduce weight and diameter size of the hand-piece. This improves the ergonomics: Treatment is comfortable, hand fatigue is minimized.

Component for dental hand-piece,  
KaVo Dental GmbH.

#### **Contents**

- 2** A higher degree of integration expands your possibilities
- 4** Flexible solution for manufacturing 3-dimensional circuitry
- 6** Integrating tomorrow's technology in today's production
- 8** Get inspired
- 10** Take advantage

# A higher degree of integration expands your possibilities

Since 1997, LPKF has developed MID technology as a laser-based procedure for the production of MID's called: The LPKF-LDS™ Process. With LPKF's Laser Direct Structuring process (LDS) it is possible to produce circuit layouts on complex three-dimensional carrier structures. The laser beam structures the layout directly into the molded plastic part. As a result, weight and fitting space can be effectively reduced. Your design teams enjoy complete 3D capability on freeform surfaces and great freedom for redesigns. Thus LPKF-LDS™ opens up new possibilities.

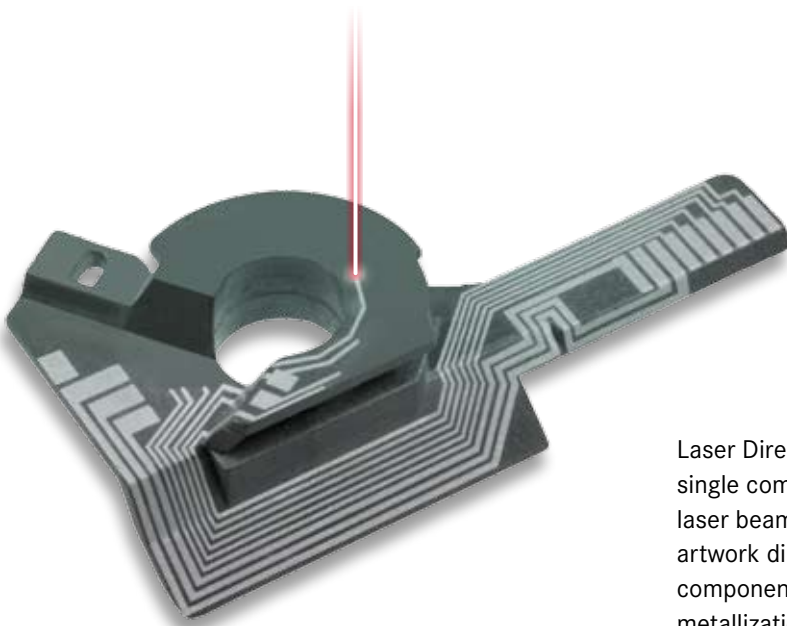

Laser Direct Structuring takes place immediately after single component injection moulding of the carrier: a laser beam takes only a few seconds to transfer the artwork directly from the computer onto the plastic component - without tools or masks. Subsequent metallization and SMD assembly operations result in highly sophisticated products.



## Flexible solution for manufacturing 3-dimensional circuitry

One of the main advantages of processing materials with laser light is the combination of defined energy input on the material with high processing speeds. The circuit layout is not predetermined by the geometry of a fixed tool. This provides shorter lead times and high levels of flexibility.

### A better product at a lower cost

2-shot injection moulding and hot stamping are already used to manufacture MIDs (Moulded Interconnect Device). Both of these methods are tied to product-specific tools to create a circuit on the component. Increasing miniaturization of the circuits on MID components leads to a considerable rise in tooling-up time and expense. Prototyping shortly before series production is almost impossible. LPKF-LDS™ technology overcomes these obstructions and helps to improve economic efficiency, even in high-production runs.

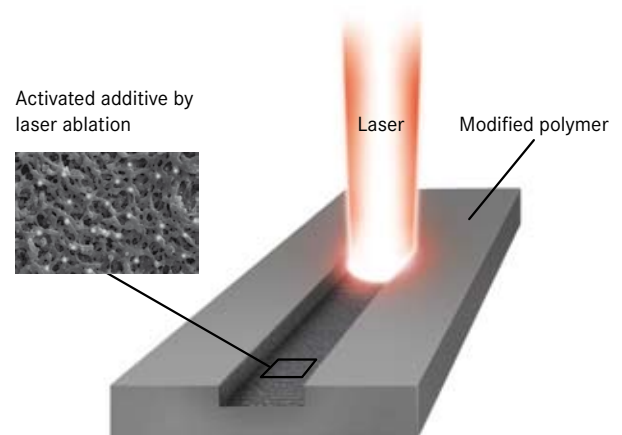

# The process steps of LPKF-LDS™

## 1. Injection moulding

The parts to be laser structured are produced using 1-shot injection moulding of commercially available doped thermoplastic. Compared to 2-shot moulding only a simple tool is needed and the moulding process is faster. Read more about the large portfolio of LPKF-LDS™-graded materials on page 10.



## 2. Laser activation

The laser-activatable thermoplastic is doped with a special additive. It is activated by the laser beam. A physical-chemical reaction forms metallic nuclei. These act as a catalyst for reductive copper plating. In addition to activation, the laser creates a microscopically rough surface in which the copper is firmly anchored during metallization.

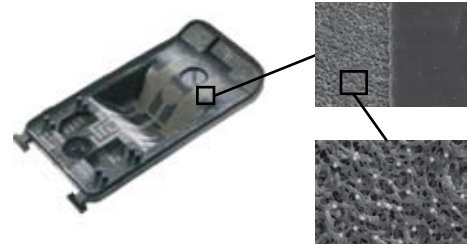

Surface after laser structuring.

## 3. Metallization

Metallization of the LPKF-LDS™ parts starts with a cleaning step. Then follows an additive build-up of the tracks typically 5 – 8 µm with the help of electroless copper baths. Lastly follows plating with currentless nickel and flash gold.

Application-specific coatings such as Sn, Ag, Pd/Au, OSP etc. can also be created.

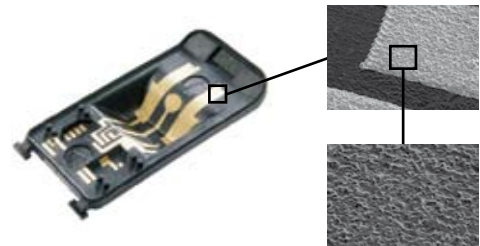

Surface after metallization.

## 4. Assembling

A number of laser-activatable plastics with high degrees of thermal stability, such as LCP, PA 6/6T or PBT/PET blend are reflow solderable and therefore compatible with standard SMT processes. Dispensing is commonly the process for application solder paste on different heights of assembling levels. Reliable technical solutions for 3D assembly operations are available today.



Bond foot on an electroless plated pad with Cu/Ni/Au.

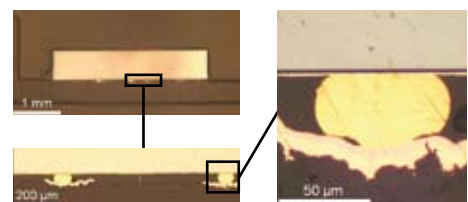

Stud bonding on an electroless plated pad with Cu/Ni/Au.



More functions, less cables in car steering wheels with LPKF-LDS™ technology; TRW Automotive.

## Integrating tomorrow's technology in today's production

The increasing amount of electronic features is a challenge for many branches and markets. The industry demands technologies to reduce dimensions and weight of components. At the same time it is necessary to simplify prototyping operations and shorten the time to market. The LPKF-LDS™ technology meets exactly these needs.

### LPKF-LDS™ for auto-motivated people

Today's cars live on the numerous sensors and electronic assistants, which improve the comfort and safety of the passengers. On the other hand the number of components and the assembly costs have to be reduced considerably. Moulded Interconnect Devices (MIDs) combined with suitable fitting and connection technologies are ideally suited to achieve these aims.

For instance, typical electro-mechanical functions such as buttons, plugs and other connection elements can be simultaneously integrated within a functional component acting as a circuit carrier. LPKF-LDS™ expands the opportunities when it comes to re-specify electrical components to achieve a more cost effective engineering and production.

## Telecommunication: get connected

Diversification, styling, miniaturization and cost reduction are trends in the field of portable electronics. End-users are expecting increasing amount of novel functions available inside trend-looking compact covers. The LPKF-LDS™ technology offers great potential for miniaturization and a very high flexibility when changing and improving functionality – especially when it comes to modifying the features into several products. This has been demonstrated millionfold with LPKF-LDS™ based internal antennas of mobile phones, portable computers etc.



LPKF-LDS™ based antennas of mobile phones – high-mix, high-volume production.

## Supporting next-generation healthcare solutions

Decreasing size and increasing performance – these market demands are relevant for many medical devices today. New skills and technologies carry on this trend: Rapid developments in software and chip technology provide new diagnostic capabilities. Utilizing these proceedings, small diagnostic applications can help to improve the life of millions of patients. They can carry along minimized diagnostic and monitoring units for medication, such as glucose meter and others. Combined with available bluetooth-technology the need to physically visit the doctor might be reduced. It is obvious, that perspectives of this kind demand new levels of smart function integration. The laser-based LPKF-LDS™ method meets exactly these needs with ultra-fine precision and high reliability.



MID technology makes healthcare devices more convenient.  
A classical LPKF-LDS™ application: State-of-the-art hearing aids.  
Made by Siemens Audiologische Technik GmbH.

# Get inspired ...

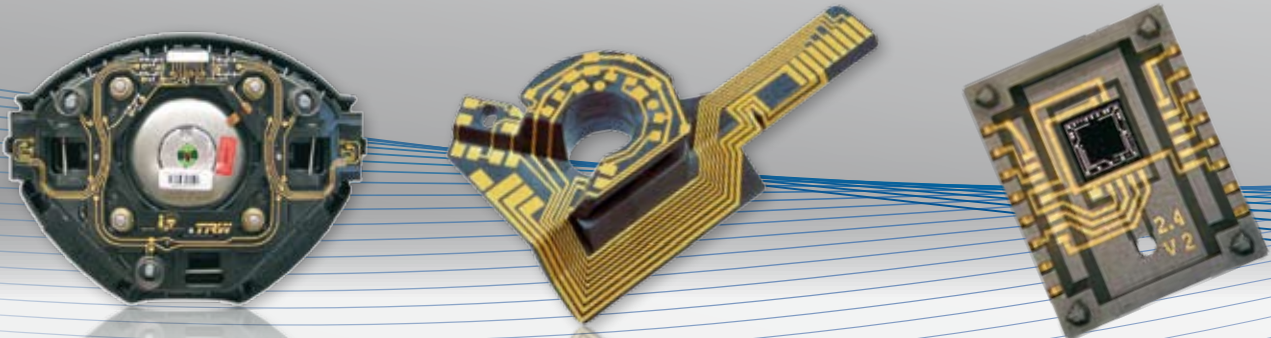

## Substitution of cable harness

If a cable harness gets more and more complex, LPKF-LDS™ assists the engineer to simplify the product in order to improve quality and reliability. The replacement of the cable harness makes the manufacturing more efficient, mounting becomes easier and faster.

## Substitution of flex-boards

When the available space is premium designers enjoy the possibility to overcome issues, which accompany flex circuit boards as e.g. complex flat projection and bending radii.

## Replacement of leadframes

Variations of the artwork can be realized by simply changing the laser program. Thus LPKF-LDS™ technology opens the door to start new platform strategies for sensor packages. Various chip sets and circuit layouts allow completely different products with the same moulded component.

The LPKF-LDS™ process enables bare die assembly with secure wire bonding and flip chip technology. The process creates the required low roughness of the metal surfaces.



Component for car steering made by TRW Automotive.

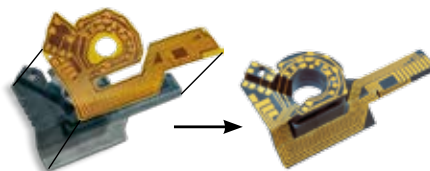

Merging of FPCB and plastic component. Made by Iskra Automobiltechnik.

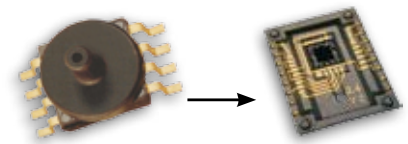

Pressure sensor for industrial application. The signal conditioning ASIC is integrated, mechanical interfaces are part of the housing. Made by Harting.

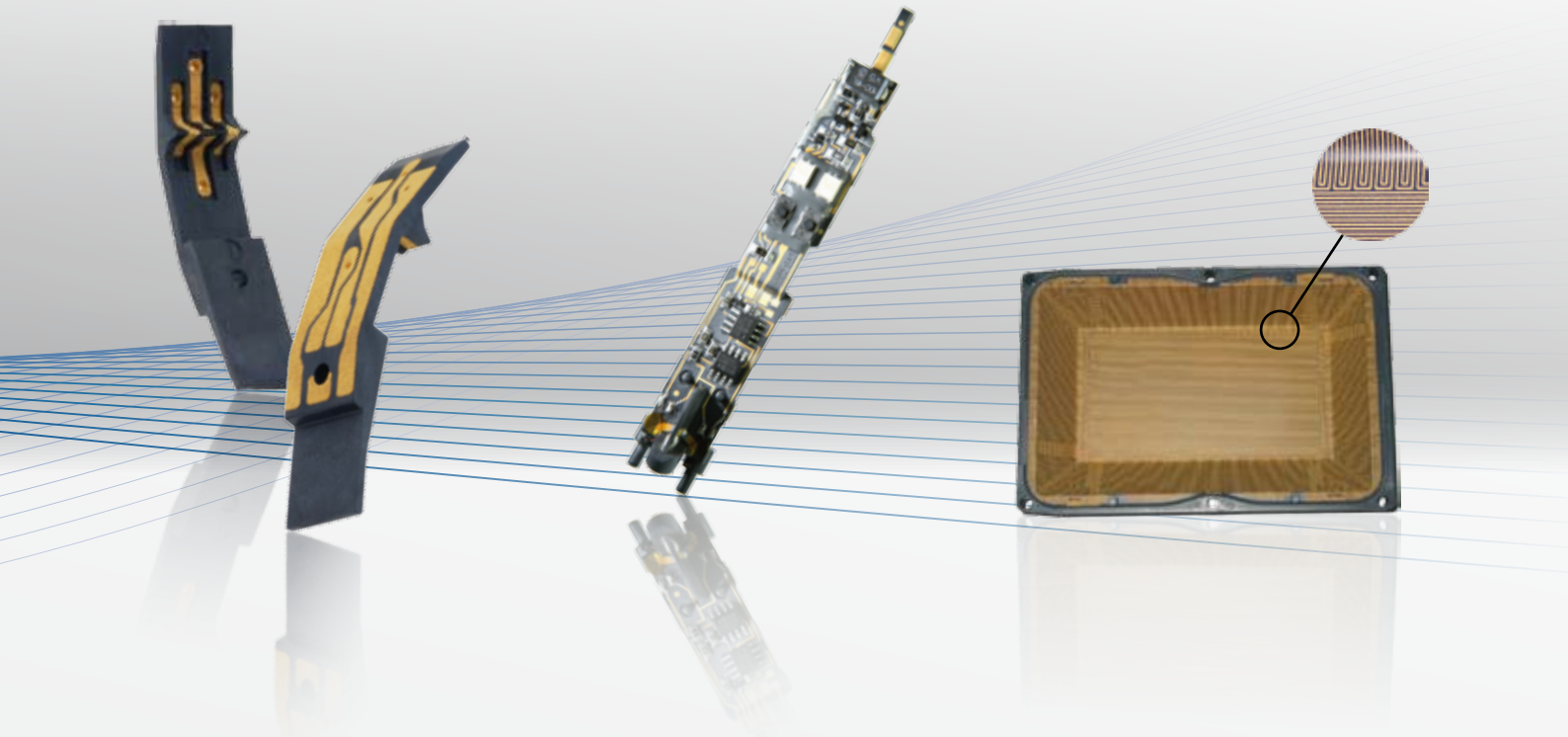

### Through-hole capability

The LDS technology can provide plated through-holes to connect surfaces of MIDs. This amplifies the layout possibilities. This way the 3D circuit board serves as an attachment body for microphones in a state-of-the-art hearing aid (see picture above).

### Compliant with SMT requirements

Products created with LPKF-LDS™ show full SMT capability. For automatic assembly lines components can be placed on flat surfaces located at stepped heights.

### Fine and finest resolution

LPKF-LDS™ provides fine pitches. Track widths of 150 µm and gaps of 200 µm have proven to be a standard in practice. Significant thinner tracks and gaps are possible depending on the intended application. The combination of fine pitches with the ability to create complex circuitry easily from layout data expands the designer's opportunities.



ø 240

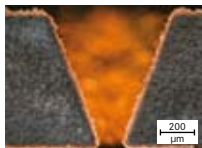

Typical LDS through-hole with an angle of 70°

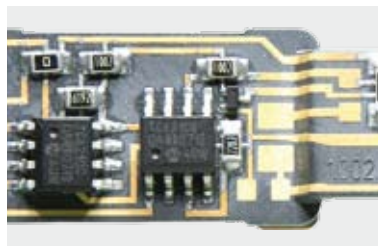

Component for dental hand-piece, KaVo Dental GmbH.

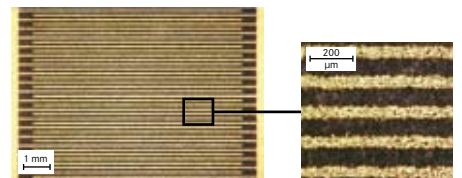

Sensor structure on LCP Vectra E820i-LDS, lines and spaces: 75 µm/75 µm.

Source: HSG-IMAT, Institute of Micro Assembly Technology. Top of the page: Harting.

Source: HSG-IMAT, Institute of Micro Assembly Technology. Top of the page: Siemens Audiologische Technik GmbH, Harting.

# Take advantage

To take full advantage of the LPKF-LDS™ technology, tried-and-tested solutions, comprehensive practical experience and support are available for all process steps. This assures the economical and uncomplicated operation of the innovative production method.

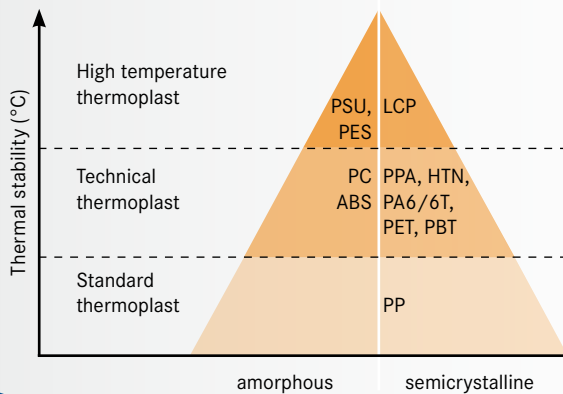

## Large material portfolio

The application-oriented selection of the laser-activatable plastics is important. A variety of manufacturers guarantee the availability of material for almost any tough requirement. Suppliers of electronic components use various materials to which they have adapted their manufacturing processes. The key material properties to be considered are processing and usage temperatures, required flammability rating, mechanical and electrical properties, mould and palatability as well as cost.

The following illustration comprises the most common LPKF-LDS™ graded substrate material. The graph does not claim to be complete.

## Benchmark 3D technology, field-proven systems

The LPKF MicroLine 3D is a laser system specially developed for the production of 3D Moulded Interconnect Devices. The ability to guide the laser beam directly along free-forming surfaces makes the LPKF-LDS™ process extremely fast – no matter how complicated the layout is. The high machine capability ensures reliable reproducibility and efficient production.



### Easy data preparation

The creation of 3D circuitry with the LPKF MicroLine 3D is supported by intuitive software. The software combines the component geometry with the circuit artwork and calculates the filling routines. It is compatible with all common data formats such as HPGL, DXF for 2D layouts and IGES, 3D DXF or STEP for 3D layouts.

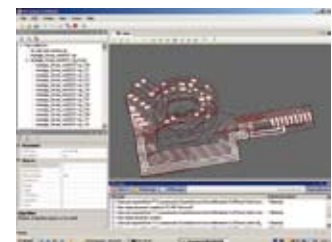

# Design-rules at a glance

Process-optimized design of the circuit carriers is essential to ensure high quality MID production and to benefit best from LPKF-LDS™ technology.

## Line and Space

One of the important goals during the development and manufacture of 3-dimensional circuitry is the efficient use of space with the finest possible structures. Track widths of  $\geq 150 \mu\text{m}$  and gaps of  $\geq 200 \mu\text{m}$  have proven ideal in practice, although thinner tracks and gaps are possible.

## Size of workpiece

The zone in which the component can be processed is limited by the maximum possible scan field volume of the laser. The scan field of the LPKF MicroLine 3D laser system for instance has a frustum with a base diameter of 160 mm, a height of 24 mm and a lateral area angle of inclination to the base of  $77^\circ$ .

## Angle of incidence

The surface of the polymer is activated by the laser light. The maximum angle of incidence of the laser beam on the surface to be structured must not be exceeded if safe activation is to be achieved. The angle of incidence is the angle between the orthogonal to the activated surface and the laser beam. Angles of incidence exceeding  $65^\circ$  are reduced by rotating the component during the laser processing step. This technique can also be used to realize artwork lying on surfaces separated by angles of  $90^\circ$ .

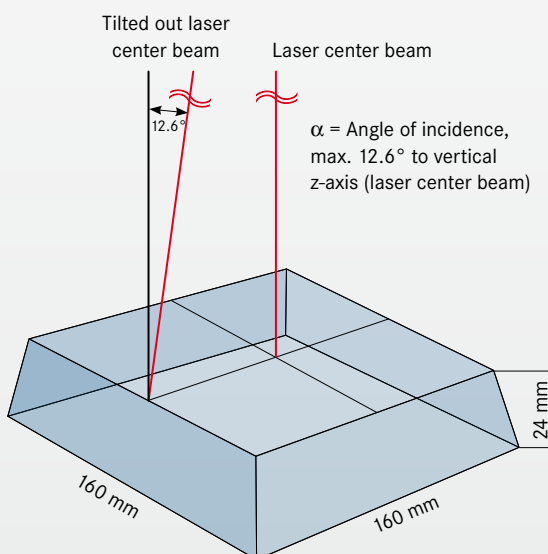

## Walls and ejection pins

Zones to be subsequently activated should not touch walls directly. The separation for walls with an angle of  $45^\circ$  should be  $\geq 150 \mu\text{m}$ , the separation from steeper walls with angles of  $70^\circ$  for instance should be  $\geq 250 \mu\text{m}$ . An adequate separation between the tracks and ejection pins must also be incorporated in the design.

## Optimum cycle times

The cycle time of each component also has to be minimized to ensure cost efficiency of the laser structuring side of the LPKF-LDS™ method. This is mainly determined by the handling time and the structuring time, which is also proportional to the layout area. The handling time is mainly determined by the number of positions into which the component has to be placed. The number of positions and the layout area should be reduced to a minimum by appropriate component design.

## Activating through-holes

To ensure that the laser can process the inside walls of the through-plated hole at a suitable angle of incidence, the vias have to be conical on one side or both sides depending on the thickness of the material. In the case of thick walls, the internal diameters of the vias must be enlarged to ensure unimpeded processing by the laser beam (aspect ratio of simple cones 1:1; for double cones 2:1).

## Fixtures, clamps and bonding seams

The components have to be fixed in place during laser structuring and assembly. The fixing positions must not harm any sensitive parts such as tracks, contact pads or component seats. Tracks must not be laid over bonding seams of the thermoplastic part.

### Global Support

LPKF-LDS™ users have service centers close by in Europe, the USA and Asia. Experts in the application center in Germany use their expertise to provide practical and knowledgeable advice including the production of samples.



The global LPKF-network for service and distribution:

- Branches/production sites
- LPKF sales/service agents

#### LPKF Worldwide (LPKF Headquarters)

LPKF Laser & Electronics AG Osteriede 7 D-30827 Garbsen Germany  
 Phone +49 (5131) 7095-0 Fax +49 (5131) 7095-90 info@lpkf.de  
 www.lpkf.com



#### North America

LPKF Laser & Electronics North America  
 Phone +1 (800) 345-LPKF Fax +1 (503) 682-71 51 sales@lpkfusa.com  
 www.lpkfusa.com

LPKF-Distributor:



Made in Germany